



LCD Module SPECIFICATION

液晶显示模组规格书

ZX2D40N42432IB144

深圳市启明显示技术有限公司

0. Revision History (修订记录)

修订内容	时间	修订人	备注

深圳市启明智显科技有限公司

1. Application (应用)

This data sheet is to introduce the specification of ZX2D40N424321B144 active matrix 16.7M color TFT LCD module. Main color LCD module is controlled by Driver IC **NV3030A**. If any problem occurs concerning the items not stated in this specification, it must be solved sincerely by both parties after deliberation. As to basic specification of driver IC refer to the IC specification and handbook.

本规格书是为了介绍 ZX2D40N424321B144 有源矩阵 16.7M 彩色 TFT LCD 模块的规格。主彩色液晶显示模块由驱动芯片 **NV3030A** 控制 本规范未尽事宜如有问题，双方必须认真协商解决。驱动 IC 的基本规格参照《IC 规格书》和相关《手册》。

2. Construction and Outline (结构与大纲)

Construction: LCD panel, Driver (COG), FPC with electric components, 4 White LED lump, prism sheet, diffuser, light guide and reflector, plastic frame to fix them mechanically. There shall be no scratches, stains, chips, distortions, and other external drawbacks that may affect the display function. To realize thin module structure, double-sided adhesive tapes are used to fix LCD panels. As these tapes do not guarantee to permanently fix the panels, LCD panel may rise from the module when shipped from factory. So please make sure to design the system to hold the edges of LCD panel by the soft material such as sponge when LCD module is assembled into the cabinet.

结构:液晶面板，驱动或 COG，带电子元件的 FPC，4 个白光 LED 块，棱镜片，扩散器，导光器和反射器，塑料框架机械固定。不应有可能影响显示功能的划痕、污迹、芯片、畸变等外部缺陷。为了实现薄型模块结构，采用双面胶带固定液晶面板。由于这些胶带不能保证永久有效固定面板，LCD 面板在出厂时可能会从模块内移动。所以在液晶模块组包装和进柜时，请务必将包装结构设计成用海绵等软材料支撑液晶面板的边缘。

3. Mechanical Specification (参数规格) Table 1 (表 1)

Item(项目)	Specifications(规格)	Unit(单位)
Screen size(屏幕尺寸)	2.4	inch
Display mode(显示模式)	Normally Black	-
Active area(显示范围)	36.72*48.96	mm
Display format(分辨率)	240xRGBx320	-
Pixel configuration(像素)	0.153*0.153	mm
Outline Dimensions(外形尺寸)	42.72 (H) *60.26 (V) *2.40 (D)	Note 1
View Angle(视角)	FULL	
Base color Notes(基色)	Black	-
Weight(重量)	TBD	
Driver IC(驱动 IC)	NV3030A	

Note 1: Not include FPCs & Bezel extrude structure.

备注 1: 不包括排线和面板构造

5. Interface signals (接口信号) Table 2 (表 2)

Pin No.	Symbol	Function 功能描述
1	GND	Ground
2	IMO	The MCU interface mode select. 0:80-8bit parallel I/F 1: 4-line 8bit serial I/F
3	VDD	Analog Power Supply for LCM
4	IOVCC	I/O Circuit Power Supply
5	LCD_ID	LCM ID 0: TN type 1: IPS type
6	GND	Ground
7	WR	Write enable in MCU parallel interface
8	RS	Display data/command selection pin in parallel interface
9	CS	Chip select pin
10	SDI	SPI interface input/output pin
11	TE	Tearing effect signal is used to synchronize MCU to frame memory
12	RESET	Chip reset signal
13	LEDA	Backlight anode
14	LEDK	Backlight cathode
15	GND	Ground
16	RD	Read enable in 8080 MCU parallel interface
17~24	DB0~DB7	MCU parallel interface data bus
25	GND	Ground
26	TP_SDA	CTP I2C serial data
27	TP_SCL	CTP I2C serial clock
28	TP_VCC	CTP Power Supply
29	TP_INT	CTP interruption signal
30	TP_RESET	CTP Reset signal

6. ELECTRICAL CHARACTERISTICS (电气特征)

6.1 ABSOLUTE MAXIMUM RATINGS (绝对最大额定值) Table 3(表 3)

Item 项目	Symbol	Value	Unit	Remark
Analog Power Supply Voltage	VCI	-0.3~+6	V	-
Digital Power Supply Voltage	VDD	-0.3~+6	V	-
I/O Power Supply Voltage	IOVCC	-0.3~4.5	V	-

6.2 Operating Conditions (工作条件) Table 4(表 4)

Item 项目	Symbol	Min. 最小	Typ. 典型	Max. 最大	Unit
Analog Supply Voltage 模拟供电电压	VCI	2.7	2.8	2.9	V
Digital Supply Voltage 数字电源电压	VDD	2.7	2.8	2.9	V
I/O Supply Voltage 接口电压	IOVCC	1.65	1.8/2.8	3.3	V
Input High Voltage 输入高电平	VIH	0.8*IOVCC	-	IOVCC	V
Input Low Voltage 输入低电平	VIL	0	-	0.2*IOVCC	V
Output High Voltage 输出高电平	VOH	0.8*IOVCC	-	-	V
Output Low Voltage 输出低电平	VOL	-	-	0.2*IOVCC	V

Note1: Please adjust VCOM to make the flicker level be minimum

Note2: TYP VCOM is only reference value. It must be optimized according to each LCM. Be sure to use VR and OP buffer on VCOM output. Please adjust VCOM to make the flicker level be minimum for getting excellent image.

6.3 Current Consumption (电流消耗) Table 5(表 5)

Parameter	Symbol	Condition	Values			Unit	Remark
			Min.	Typ.	Max.		
Digital Current	IVDD	VDD= 3.3V	-	50	-	mA	
Total Power Consumption	PC		-	TBD	TBD	mW	

7. LED back light (背光灯) Table 6(表 6)

At main panel the back light uses 4 pcs edge light type white LED. 在背光的主面板用 4 颗白色 LED 灯

Item	Symbol	Min.	Typ.	Max.	Unit
LED Current 背光电流	IB	-	80	-	mA
LED Voltage 背光电压	Vf	-	3.2	-	V
Power Consumption 功耗	PBL	-	-	-	mW

Note:

*8 pcs of LED

*Please consider Allowable Forward Current on used temperature *4 颗灯

* 请考虑允许范围内的正向电流的使用温度

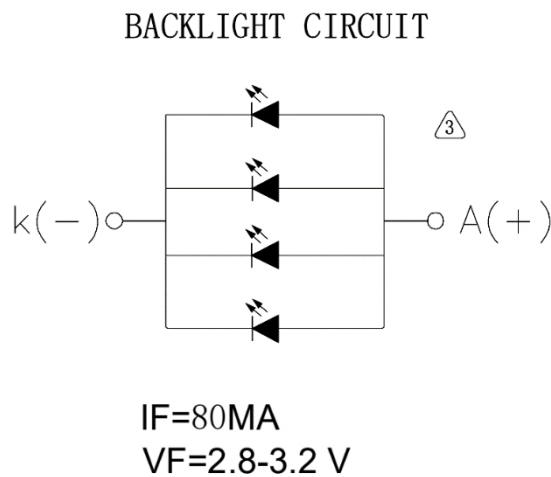

Fig.3*Schematics drawing of lighting (绘制照明图 图.3)

8. Optical Characteristics (光学特征) Table 7 (表 7)

Item	Symbol	Condition	Min.	Typ.	Max.	Unit	
Viewing Angle Range 视角	Left	θ_L	-	80	-	degree	
	Right	θ_R	-	80	-		
	Top	θ_T	-	80	-		
	Bottom	θ_B	$CR \geq 10$	-	80		-
Response Time 响应时间	Ton+Toff	$\theta = \Phi = 0^\circ$	-	30	40	ms	
Contrast Ratio 对比度	CR	$\theta = \Phi = 0^\circ$	-	250	-	-	
Luminance 亮度	L	$\theta = \Phi = 0^\circ$	-	300	-	cd/m ²	
Color Chromaticity (CIE1931) 色坐标	White	W_x	Normal $\theta = \Phi = 0^\circ$	-0.02	0.308	+0.02	-
		W_y			0.325		
	Red	R_x			0.612		
		R_y			0.329		
	Green	G_x			0.299		
		G_y			0.567		
	Blue	B_x			0.144		
		B_y			0.110		
Uniformity 均匀度	U_L	$\theta = \Phi = 0^\circ$	80	-	-	%	
Flicker 闪烁	-	-	-	No Visible	-	-	

9. General Precaution (一般注意事项)

9.1 Safety

1. Do not swallow any liquid crystal, even if there is no proof that liquid crystal is poisonous.
2. If the LCD panel breaks, be careful not to get liquid crystal to touch your skin.
3. If skin is exposed to liquid crystal, wash the area thoroughly with alcohol or soap.

9.2 Storage Conditions

1. Store the panel or module in a dark place where the temperature is $23\pm 5^{\circ}\text{C}$ and The humidity is below $50\pm 20\%RH$.
2. Store in anti-static electricity container.
3. Store in clean environment, free from dust, active gas, and solvent.
4. Do not place the module near organics solvents or corrosive gases.
5. Do not crush, shake, or jolt the module.

9.3 Handling Precautions

1. Avoid static electricity which can damage the CMOS LSI.
2. The polarizing plate of the display is very fragile. So, please handle it very carefully.
3. Do not give external shock.
4. Do not apply excessive force on the surface.
5. Do not wipe the polarizing plate with a dry cloth, as it may easily scratch the surface of plate.
6. Do not use ketonic solvent & Aromatic solvent, use with a soft cloth soaked with a cleaning naphtha solvent.
7. Do not operate it above the absolute maximum rating.
8. Do not remove the panel or frame from the module.
9. When the module is assembled, it should be attached to the system firmly, be careful not to twist and bend the module.
10. Wipe off water droplets or oil immediately. If you leave the droplets for a long time, staining and discoloration may occur.
11. If the liquid crystal material leaks from the panel, it should be kept away from the eye so mouth in case of contact with hands, legs or clothes, it must be head way thoroughly with soap.

9.4 Warranty

1. The period is within twelve months since the date of shipping out under normal using and storage conditions.
2. Do not repaired or modified the LCM. It may cause function to lose efficacy, Starry does not warrant the LCM.
3. All process and material comply ROHS.

10. Contact information (联系信息)

网址: [http://www. panel-tag.cn/](http://www.panel-tag.cn/)

联系邮箱: panlee@smartpanle.com

样品购买地址: <https://shop212317088.taobao.com/>

微信公众号: 启明智显



有限公司

深圳市启明智显